

WORKING PRESSURE:
33,4mbar - 3340Pa

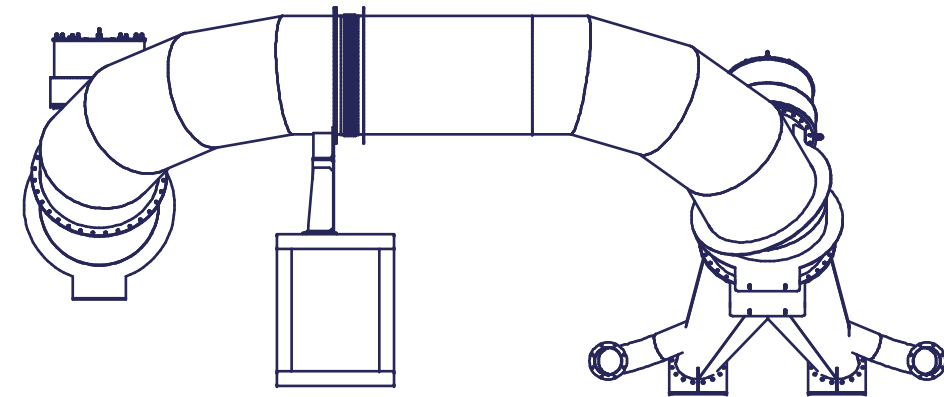

AC-AC (1 : 20)
INLET/OUTLET FLANGE

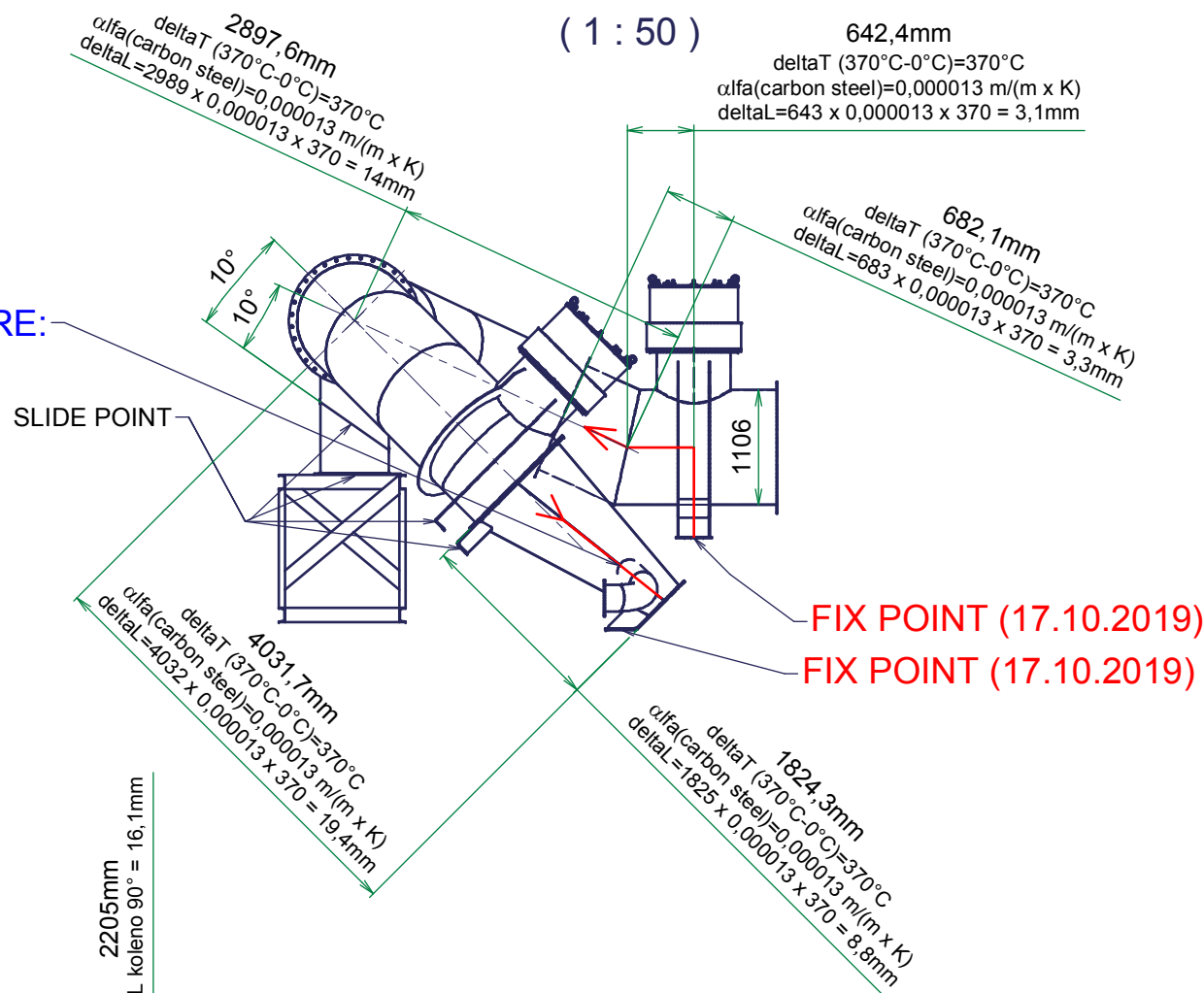
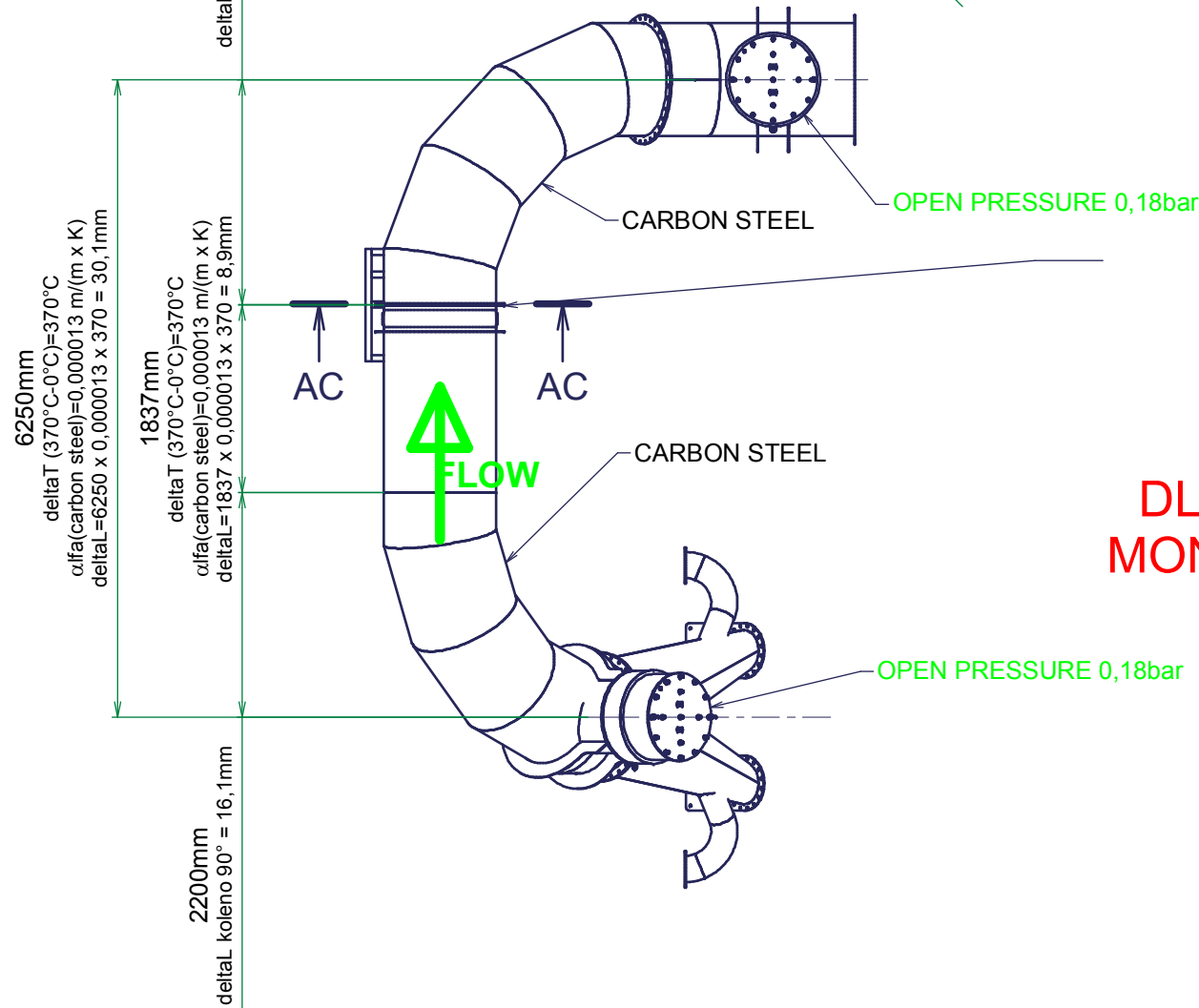
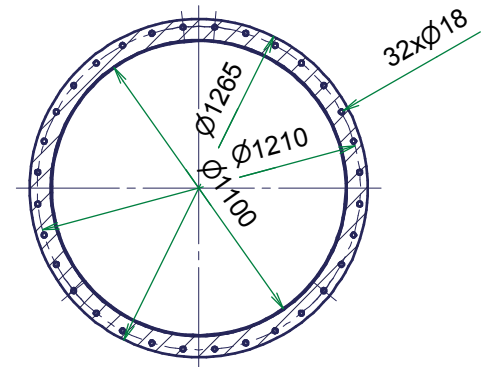

K6
AXIAL= -41,1mm
LATER= 10 mm
ocelova ochranna rura
DLZKA TKANINY = 200mm
MONTAZNA DLZKA = 200mm

						Nadradené zostavy:
Číslo zmeny	Zmena	Platí od	Dátum	Zmenil		
Rozmer polotovaru:						
Vypracoval: BERNAT			Materiál:			
Názov: MONTAZ VYFUKOVEHO MODULU						
Číslo výkresu: 7104-70-9003		Hmotnosť: 26673,150 kg		Mierka:		
Dátum: 30. 5. 2019	List: 8	Listov: 9	Formát listu: A2			
Súbor: montaz_vyfukoveho_modulu_7104-70-9003.iam						