

WORKING PRESSURE:
2,5mbar - 250Pa
3mbar - 300Pa

(1 : 50)

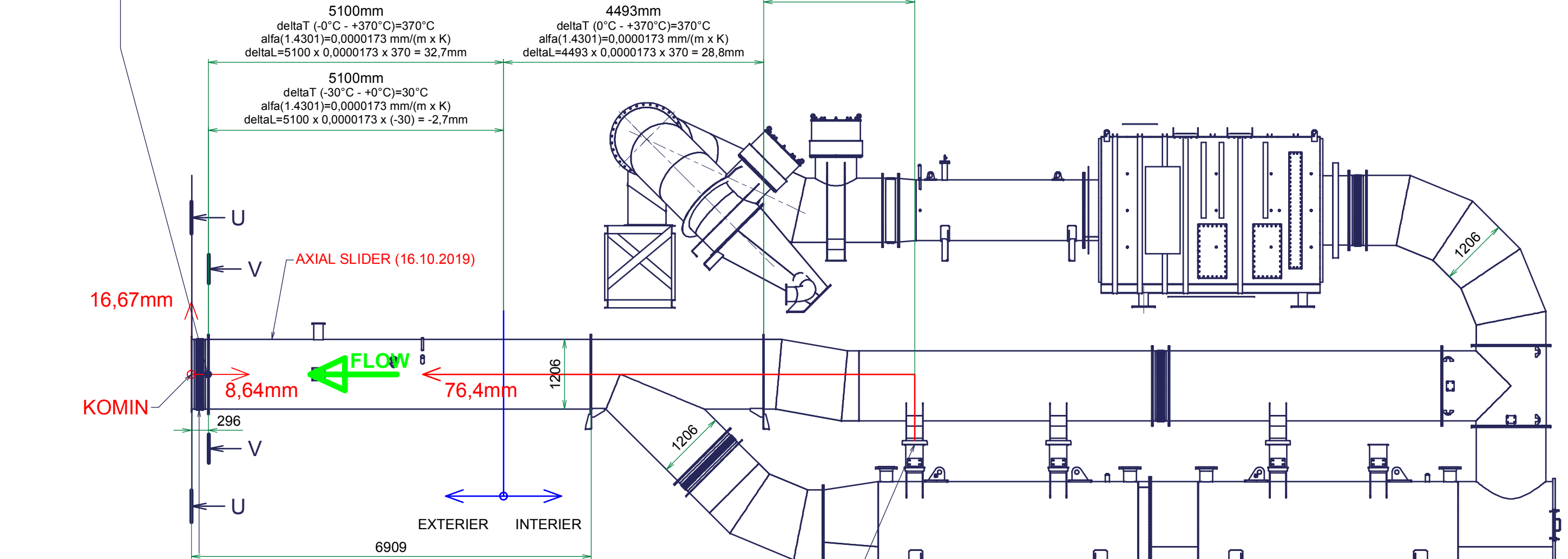

K3

AXIAL= - 82,74mm

AXIAL= + 2,7mm

LATER= 16,67mm

1.4301 ochranna rura

DLZKA TKANINY= 330mm

MONTAZNA DLZKA = 289,294,301,306mm

25.11.2019

U-U (1 : 25)
OUTLET FLANGE

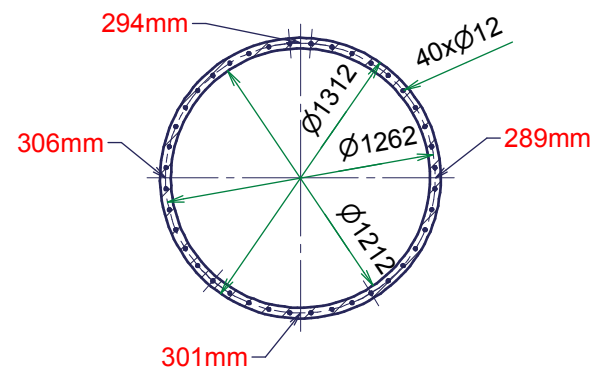

V-V (1 : 25)
INLET FLANGE

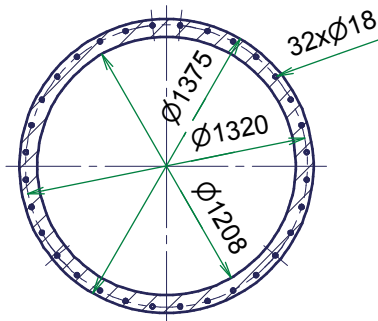

						Nadradené zostavy:
Číslo zmeny	Zmena	Platí od	Dátum	Zmenil		
Rozmer polotovaru:						
Vypracoval: BERNAT			Materiál:			
Názov: MONTAZ VYFUKOVEHO MODULU						
Číslo výkresu: 7104-70-9003		Hmotnosť: 26673,150 kg		Mierka:		
Dátum: 30. 5. 2019	List: 5	Listov: 9	Formát listu: A2			
Súbor: montaz_vyfukoveho_modulu_7104-70-9003.iam						